



LED Emergency Wall Pack Fixture



Application: The ideal commercial or industrial solution for entrance lighting, courtyard lighting, outdoor landscape lighting, wall lighting, and various other applications.

Certification



Feature

- 24-hour backup battery recharge time and over 90-min. emergency operation during a power outage
- Lens: Non-yellowing and durable polycarbonate, IK08 Vandal Resistant Rating & UV Resistant
- Corrosion resistant die cast aluminum housing
- Type IV light distribution pattern and 100° Beam angle
- UL and IP65 rated for dust, moisture, and water resistance

Dimension

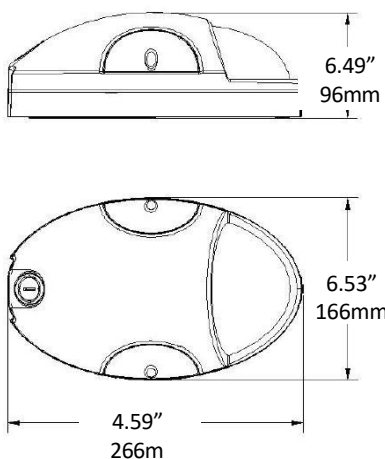

Specifications

Model	HYA-MWP-15W-EM-35/40/50(PC)
Wattage	15W (70-Watt metal halide equivalent)
Dimming	0-10V
Lumen Output	1800 lm (620lm at EM Mode)
Input Voltage	AC100-277V 50/60Hz
CCT	3500K-4000K-5000K Selectable
CRI	Ra>80
Working Temperature	~32°F ~+113°F / ~0°C ~+45°C
Environment Location	Wet Locations (IP65)
Driver Surge protection	L/N-PE: 2.5kV, L-N: 2.5kV
Life Span	Lumen Maintenance over 70% @ 50,000+ Hours
Lamp Shell	Dark Bronze
Accessories Option	PC: Integrated dusk-to-dawn photocell
DLC ID	DLC Premium (S-JYCLH4)
PCS/BOX	10
Master Box Dimension	532*360*295mm / 20.9"x14.17"x11.6"
Master Box Weight	14.6KG / 32.18 LB

Photometric

Luminaire Property

Luminaire Manufacturer:
Luminaire Category:
Lamp Catalog:
Number of Lamps:
Luminous Length (mm):
Luminous Height (mm):
Current: 0.113 A
Power Factor: 0.987

Luminaire Description:
Lamp Description:
Lumens per Lamp:
Luminous Width (mm):
Voltage: 120.0 V
Power: 13.35 W

Photometric Results

IES Classification: Type IV
Total Rated Lamp Lumens: 1740.0 lm
Efficiency: 100%
Upward Ratio: 8%
C0r0 Intensity: 557.43 cd
Pos of Max. Intensity: H90 V31

Longitudinal Classification: Very Short
Measurement Flux: 1740 lm
Downward Ratio: 92%
Luminaire Efficacy Rating (LER): 130.39
Max. Intensity: 781.05 cd

Luminous Intensity Distribution Curve

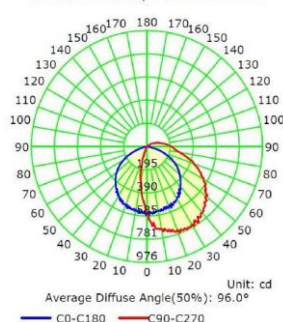

The Average Illuminance Effective Figure

